

MARLIN 3D

LASER SERIES

$\varnothing \pm 0.001$

außergewöhnlich.

HARD.



Z ZECHA

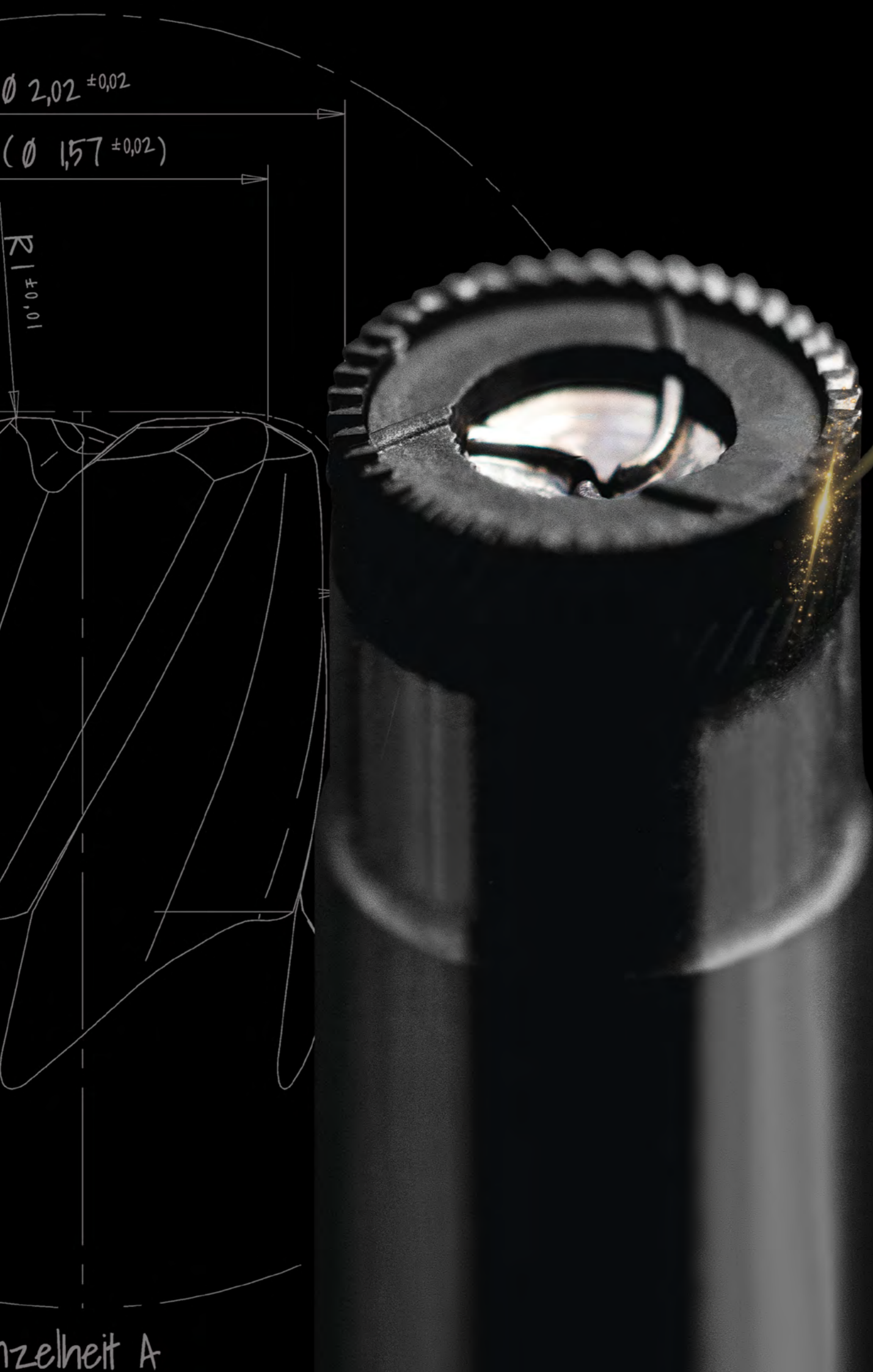

anzelheit A



ZECHA
außergewöhnlich.

MARLIN 3D

LASER SERIES

$(\varnothing 1,57 \pm 0,02)$

$R1 \pm 0,01$

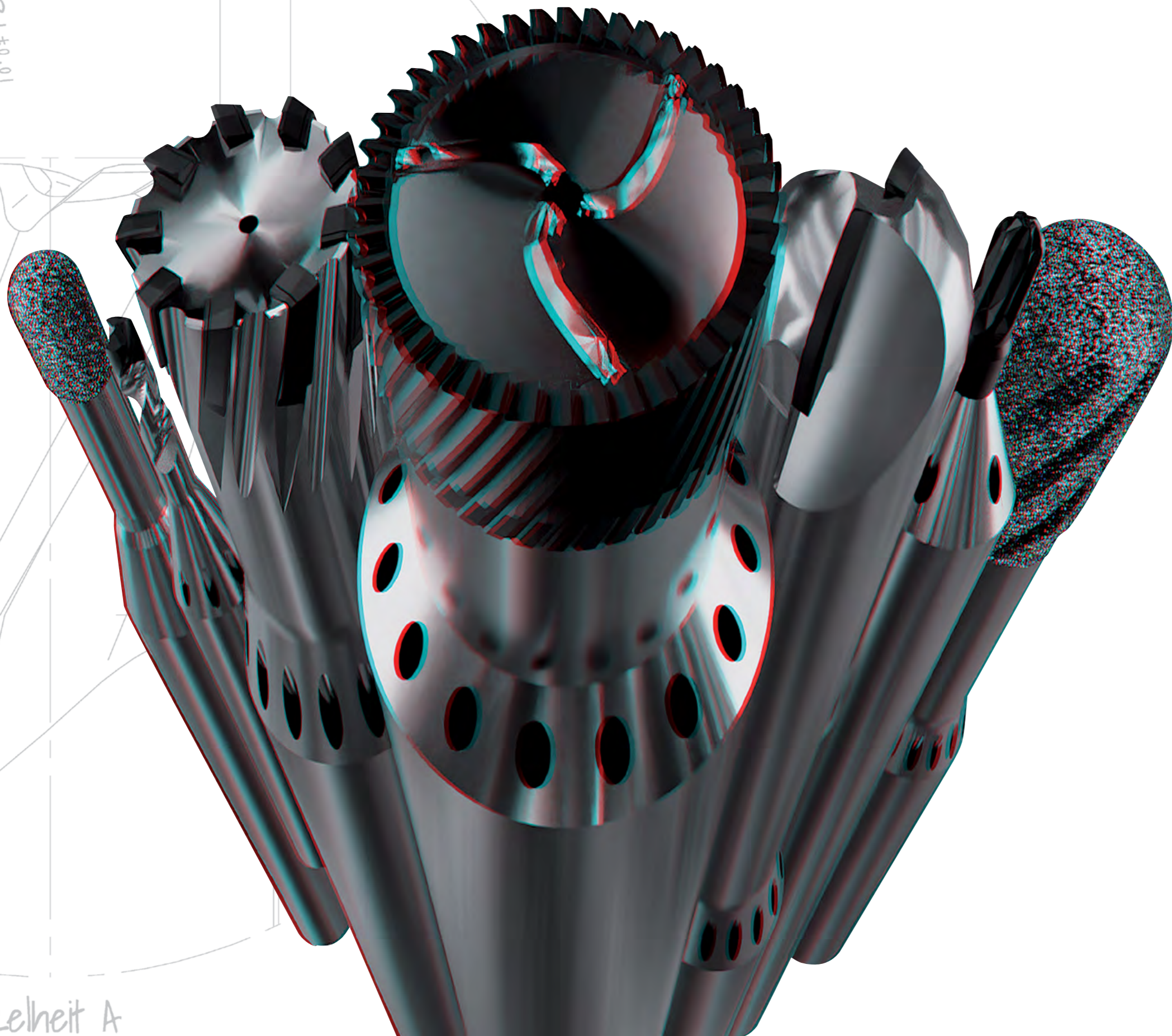

MARLIN 3D LASER SERIES

MACHINING OF ULTRA-HARD MATERIALS

ZECHA presents the new MARLIN 3D LASER SERIES, an innovative solution for machining ceramics and solid carbide.

The latest laser technology offers decisive advantages and flexibility to produce highly precise, complex and detailed 3D tool geometries. This novel series revolutionizes tool design and improves efficiency.

PCD and CVD blanks or cutting materials made entirely of PCD or CVD are used for ball nose and torus mills and drilling tools.

Our commitment to innovation and quality is reflected in every aspect of the MARLIN 3D LASER SERIES.

Feel free to contact us, we will happily advise you further!

MARLIN 3D

LASER SERIES

($\varnothing 1,57 \pm 0,02$)

R1 $\pm 0,01$



15°

Anzeilheit A

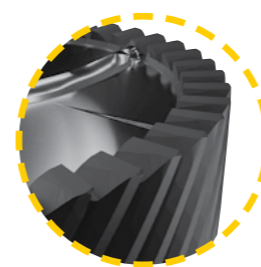

GEOMETRIES & CUTTING EDGES

ADVANTAGES DUE TO EXTRA FLUTES

The MARLIN 3D LASER SERIES is specially designed for more demanding applications and has a large number of teeth and chip chambers.

An example of this is a milling tool with a diameter of 6 mm and 42 flutes. This enables high feed rates and a large metal removal rate. The cycle times are thus significantly reduced, resulting in exceptionally high productivity.

A precise and fine geometry of the cutting tools significantly reduces the cutting forces during

the machining process. Heat generation is thus reduced and mold service life increased. This has a positive effect on the overall process reliability.

This precise geometry results in higher efficiency, which is reflected in excellent edge formation, precise dimensions and shapes, and outstanding surface quality of the component.

MARLIN 3D

LASER SERIES

$(\varnothing 1,57 \pm 0,02)$

$R1 \pm 0,01$

15°

anzelheit A

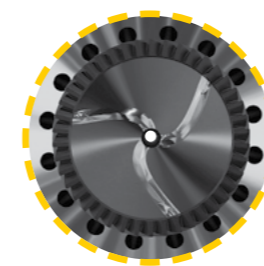

INTEGRATED COOLING SYSTEM

TEMPERATURE AND CHIP CONTROL

The use of cooling lubricants from the shank cooling channels achieves targeted and uniform placement on the tool cutting edges even at high rotational speeds.

A central axial internal cooling thereby flushes all chips and particles out of the cutting zone and contributes to temperature control during the cutting process.

The wave-shaped wiper design on the face reinforces the acceleration of the high-pressure coolant flow to the outside and further improves chip evacuation.

Thanks to the intensive cooling lubrication, friction and tool wear are minimized while tool life, surface quality and productivity are increased.

MARLIN 3D

LASER SERIES

($\varnothing 1,57 \pm 0,02$)

R1 $\pm 0,01$

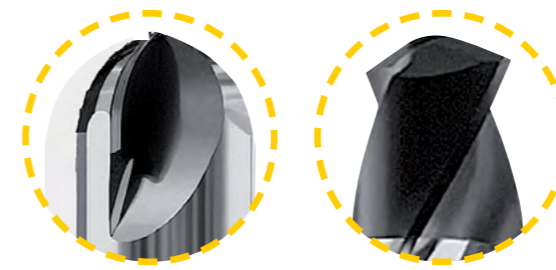
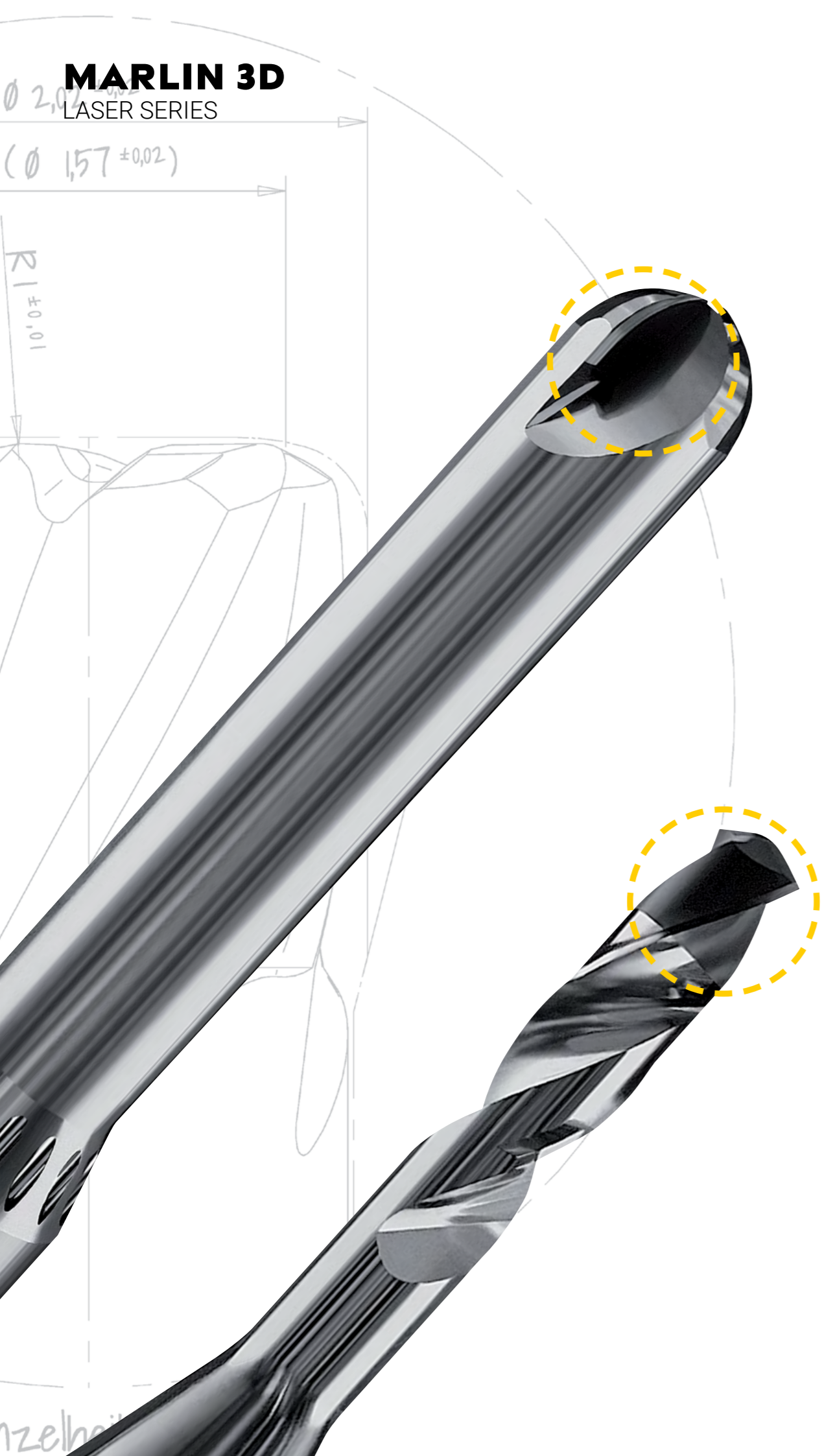

CVD VS. PCD DIAMOND BLANKS

CVD and PCD inserts are among the diamond cutting materials developed for use in high-performance cutting applications. Although they share the same objective, they differ in composition and properties.

CVD diamond inserts are produced by a chemical vapor deposition process that deposits a diamond film on a tungsten carbide substrate. Featuring a high diamond content, these tools offer excellent wear resistance, thermal conductivity and hardness. They are particularly suitable for cutting materials with abrasive properties or high machining difficulty, such as composites, ceramics and non-ferrous metals.

In contrast, PCD inserts are produced by sintering diamond powder and a metallic binder under high pressure and temperature.

The resulting material is a dense, hard and wear-resistant diamond composite that is ideal for machining cast iron, sintered carbides and ceramics.

In summary, both CVD and PCD inserts can be used for demanding cutting operations. However, they are each optimized for specific materials and cutting conditions.

CVD diamond inserts are particularly suitable for machining abrasive and difficult-to-machine materials, while PCD inserts are ideal for hard and abrasive materials.

MARLIN 3D

LASER SERIES

$\varnothing 2,02$
 $(\varnothing 1,57 \pm 0,02)$

$R1 \pm 0,01$

15°

anzelheit A

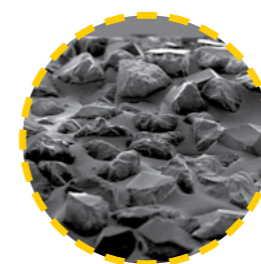

DIAMOND-COATED GRINDING PINS WITH IC + SC

High stock removal rates are crucial for the economical machining of solid carbides and hard ceramics. A circumferentially dressed contour without raised grains enables a low finishing allowance.

Optimum temperature control at the point of use can be achieved by combining internal and shaft cooling.

In addition, sufficient cooling (e.g. by surge cooling) must be provided.

In order to relieve the pressure during machining and to achieve a resetting effect of new grains, an interrupted cut in the contour is recommended. This measure removes the material more evenly, resulting in improved surface quality.

MARLIN 3D

LASER SERIES

($\varnothing 1,57 \pm 0,02$)

R $\pm 0,01$

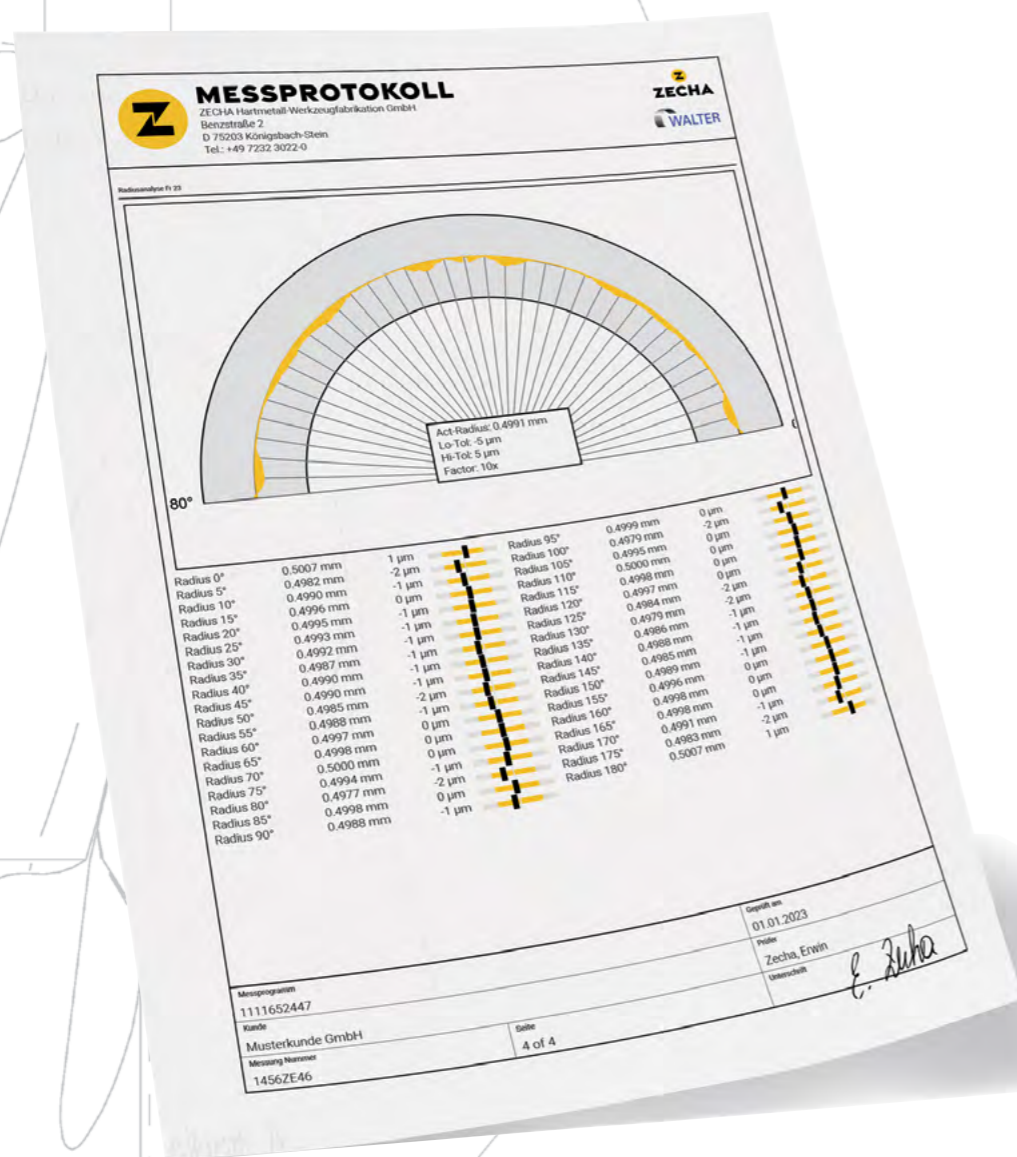

*On demand

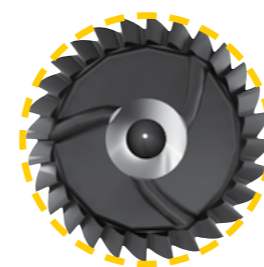

ABSOLUTE ACCURACY

ZECHA's commitment to precision and accuracy is reflected in every aspect of the MARLIN 3D LASER SERIES.

To ensure that each tool in the series meets our high standards, we provide a measurement protocol* of the tool contour.

With the extended measurement protocol, a more precise analysis of the shape accuracy of the tool is made possible, resulting in higher milling accuracy. Through exact tool compensation, improved precision is achieved, which has a

positive effect on the quality of the end product.

The comprehensive measurement protocol allows us to ensure that every tool in the MARLIN 3D LASER SERIES meets our stringent quality requirements and performs at the highest level. The combination of advanced geometries and efficient cooling options makes the 3D series the optimal solution for modern machining tasks.

When it comes to unmatched precision, quality and performance, the MARLIN 3D LASER SERIES is the right choice.

anzelheit A

MARLIN 3D

LASER SERIES

$\varnothing 2,02$
 $(\varnothing 1,57 \pm 0,02)$

$R1 \pm 0,01$

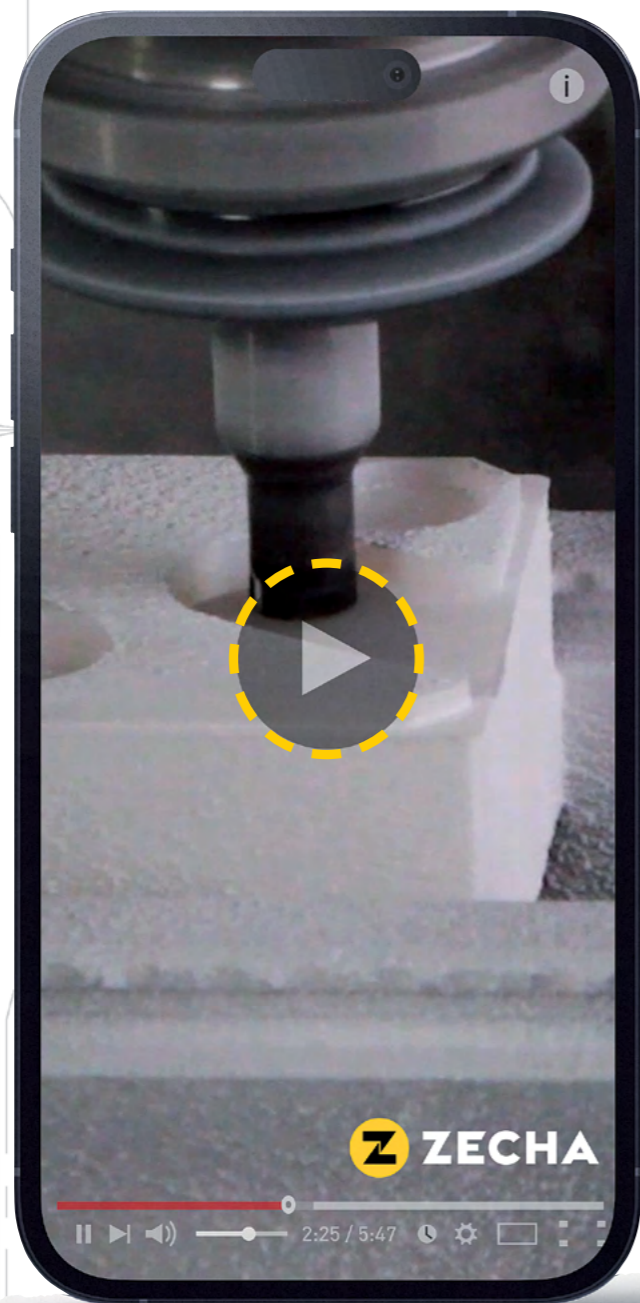

MARLIN DEMO IN SINTERED ZIRCONIA

We cordially invite you to experience the MARLIN 3D LASER SERIES in action. We are aware that you must see it, to believe it, so we invite you to visit our YouTube channel and see for yourself how our MARLIN 3D SERIES mills sintered zirconia. Just scan the QR code below and dive into the world of MARLIN 3D technology.

Watch the video to learn how the 3D series can revolutionize your machining processes with its impressive performance and precision.

Be inspired by the possibilities that the 3D series offers you.

Experience the MARLIN 3D LASER SERIES' advanced geometries and efficient cooling options and see for yourself the many benefits it offers. Extended tool life, shortened cycle times and increased productivity are just some of the positive effects you can achieve by using the MARLIN 3D LASER SERIES.

anzelheit A

MARLIN 3D

LASER SERIES

SERIES OPTIONS

Numerous variations are available in the MARLIN 3D LASER SERIES, which we will break down for you below. Here you will find a brief explanation of the different tool series as well as relevant symbols for the properties of the tools. More information about the series and a key explaining the different symbols can be found on the following pages.

960C SERIES

CVD ball nose end mill, 2 flutes with integrated shank cooling

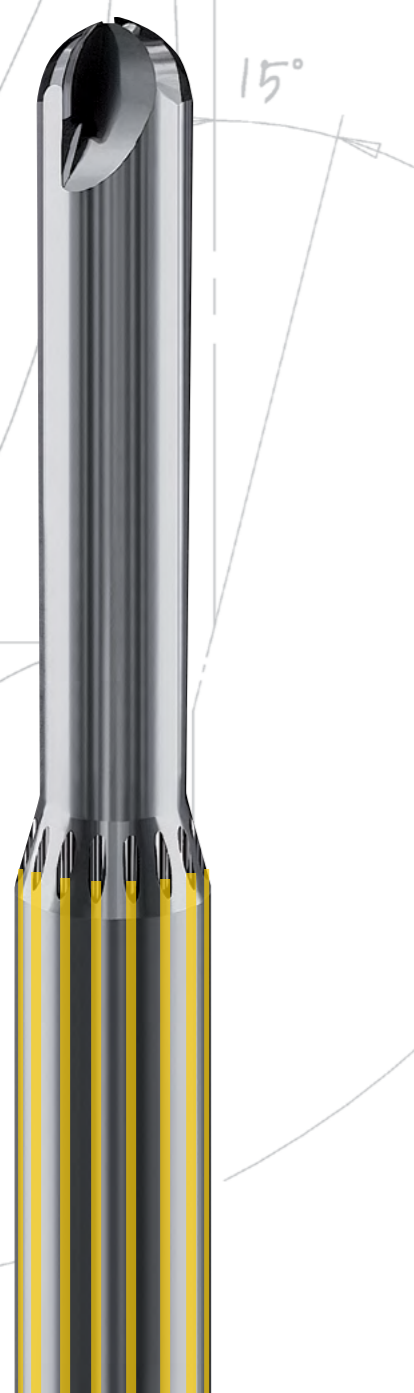

- K
- VHM
- CU
- CVD**
- [Flute symbol]
- [Flute symbol]
- [Flute symbol]
- [Flute symbol]

965C SERIES

CVD torus cutters with 3 to 9 cutting edges and integrated shank cooling from a cutting edge



- K
- VHM
- G
- CU
- CVD**
- [Flute symbol]
- [Flute symbol]

962P.B SERIES

PCD ball nose end mills with 3 to 6 cutting edges

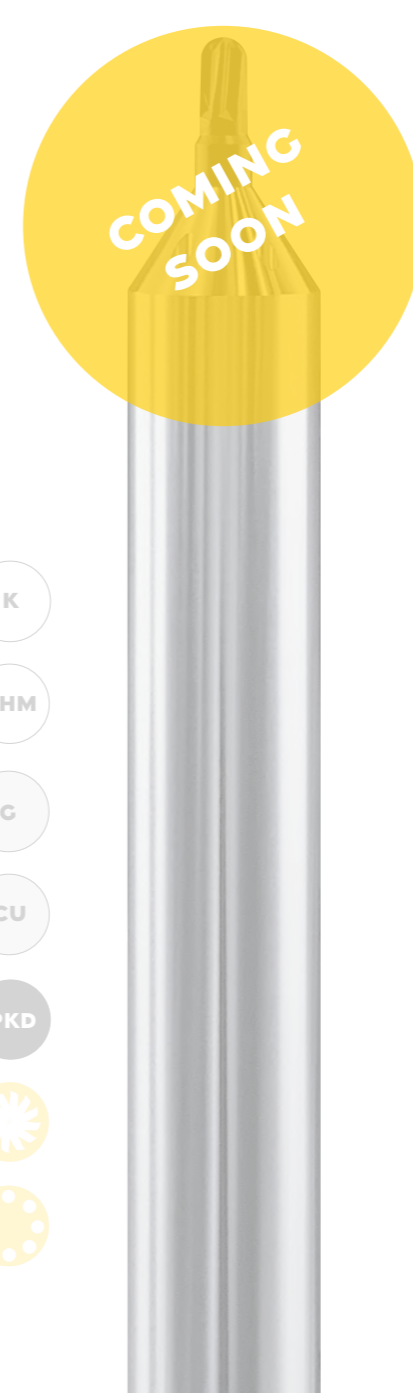

- K
- VHM
- G
- CU
- PKD**
- [Flute symbol]
- [Flute symbol]

962P.T SERIES

PCD end mill with corner radius, 3 to 9 flutes with integrated shank cooling



- K
- VHM
- CU
- PKD**
- [Flute symbol]
- [Flute symbol]
- [Flute symbol]
- [Flute symbol]
- [Flute symbol]

anzelheit A

MARLIN 3D

LASER SERIES

$\varnothing 2,02$
 $(\varnothing 1,57 \pm 0,02)$

$R1 \pm 0,01$

SERIES OPTIONS

966P.T SERIES

PCD end mill with corner radius, 14 to 42 flutes with integrated shank and internal cooling

15°

K

VHM

CU

PKD



971P SERIES

PCD twist drill, 2 flutes with integrated shank cooling

K

VHM

CU

PKD



9910 SERIES

Toric grinding pin with processed diamond coating for uniform grit height on face and circumferential surface

K

VHM

DIA



9911 SERIES

Toric grinding pin with processed diamond coating for uniform grit height and integrated shank and internal cooling

K

VHM

DIA



anzelheit A

MARLIN 3D

LASER SERIES

($\varnothing 1,57 \pm 0,02$)

R1 $\pm 0,01$

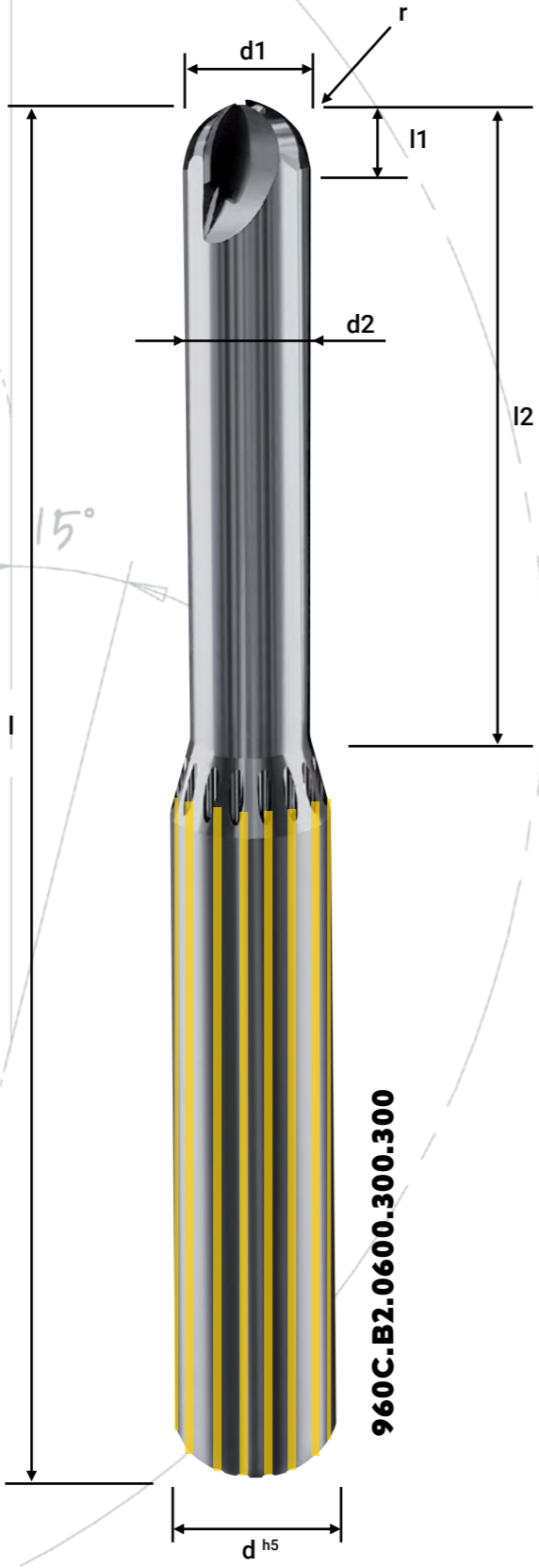

960C.B2.0600.300.300

MARLIN 960C.B2 SERIES

- CVD ball nose end mill, 2 flutes, hard-cut geometry, 0° helix angle
- Integrated shaft cooling
- For dry or wet pre-finishing/finishing of solid carbide, ceramics
- Also suitable for machining copper
- Neck extension or reduction of the total length upon request



Article number	d1	d2	r	l1	l2	d	l	Z
960C.B2.0150.075.040	1.5	1.40	0.75	1.0	4.0	6.0	60	2
960C.B2.0150.075.150	1.5	1.40	0.75	1.0	15.0	6.0	60	2
960C.B2.0200.100.080	2.0	1.90	1.00	1.5	8.0	6.0	60	2
960C.B2.0200.100.200	2.0	1.90	1.00	1.5	20.0	6.0	60	2
960C.B2.0300.150.090	3.0	2.90	1.50	2.0	9.0	6.0	60	2
960C.B2.0300.150.180	3.0	2.90	1.50	2.0	18.0	6.0	60	2
960C.B2.0400.200.120	4.0	3.90	2.00	2.5	12.0	6.0	60	2
960C.B2.0400.200.150	4.0	3.90	2.00	2.5	15.0	6.0	60	2
960C.B2.0400.200.240	4.0	3.90	2.00	2.5	24.0	6.0	60	2
960C.B2.0400.200.250	4.0	3.90	2.00	2.5	25.0	6.0	60	2
960C.B2.0500.250.150	5.0	4.90	2.50	3.0	15.0	8.0	60	2
960C.B2.0600.300.180	6.0	5.90	3.00	3.5	18.0	8.0	60	2
960C.B2.0600.300.300	6.0	5.90	3.00	3.5	30.0	8.0	60	2

anzelheit A

MARLIN 3D

LASER SERIES

($\emptyset 1,57 \pm 0,02$)

R $\pm 0,01$

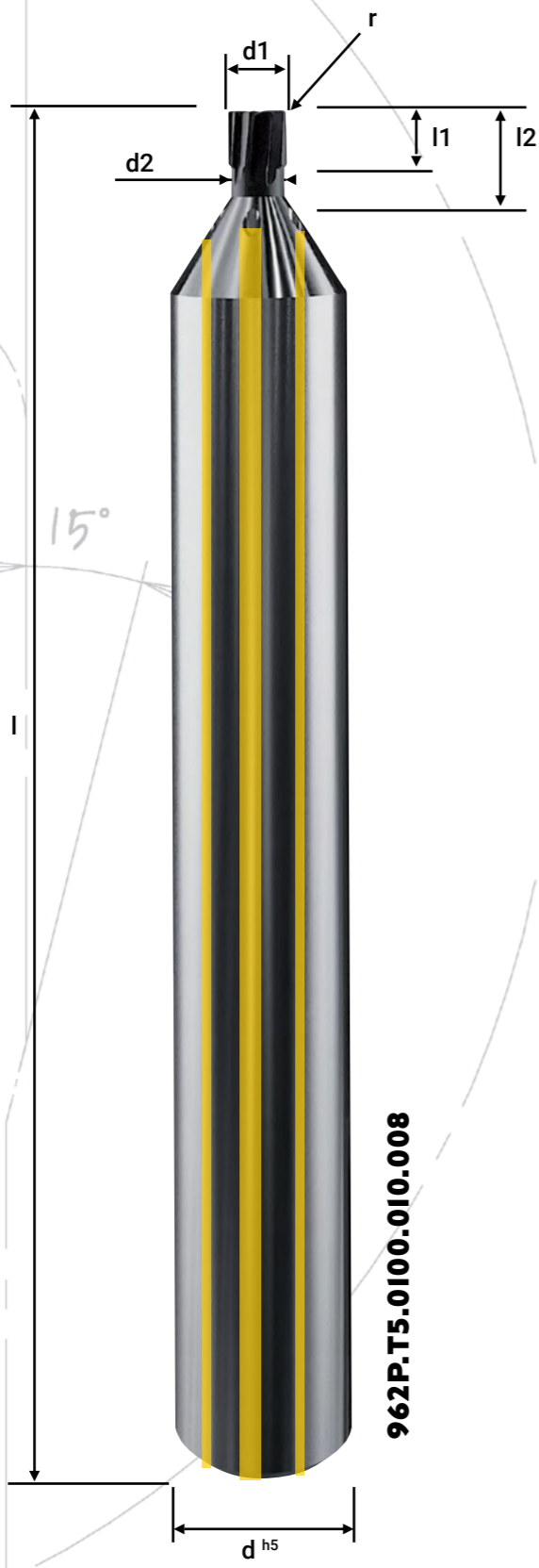

962P.T5.0100.010.008

MARLIN 962P.T SERIES

- PCD end mill with corner radius, 3 to 9 flutes, hard-cut geometry
- Integrated shank cooling or shank cooling + wiper design
- For wet pre-finishing/finishing of solid carbide, ceramics
- Also suitable for machining copper



Article number	d1	d2	r	l1	l2	d	l	Z
962P.T3.0050.005.007	0.5	0.5	0.05	0.7	0.7	4.0	43	3
962P.T5.0100.010.008	1.0	1.0	0.10	0.8	0.8	4.0	43	5
962P.T9.0200.010.017 ¹	2.0	2.0	0.10	1.7	1.7	6.0	49	9

anzelheit A

MARLIN 3D

LASER SERIES

($\varnothing 1,57 \pm 0,02$)

R1 $\pm 0,01$

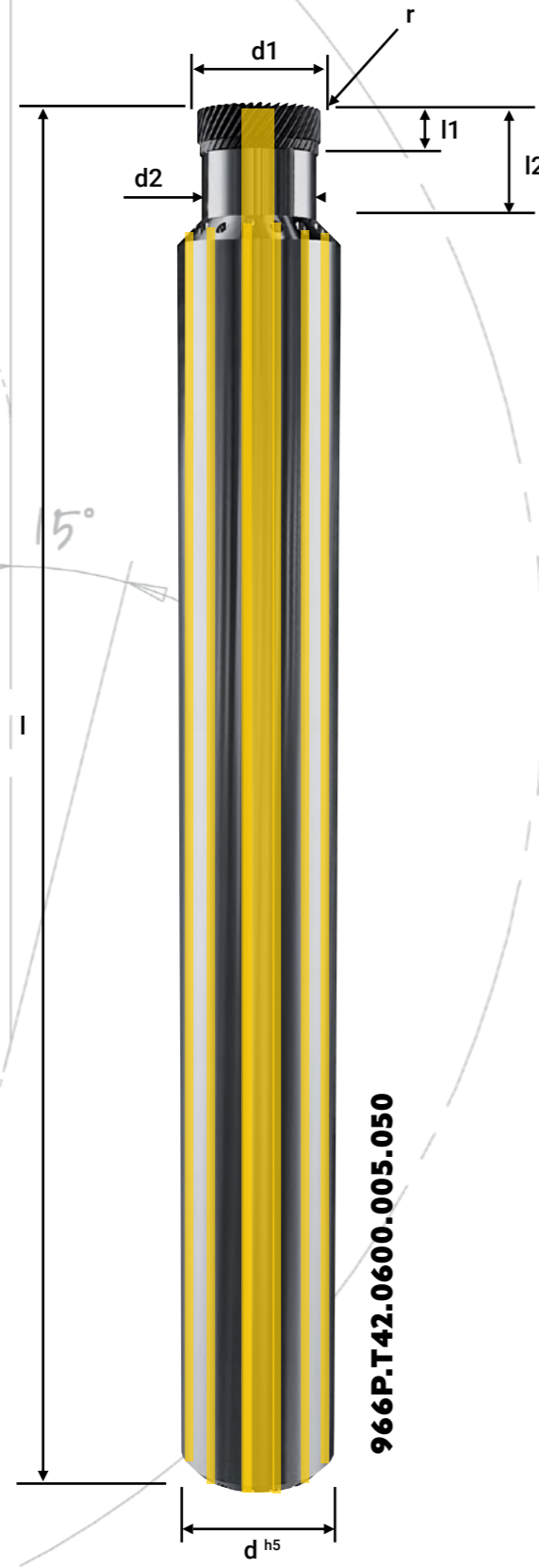

966P.T42.0600.005.050

MARLIN 966P.T SERIES

- PCD end mill with corner radius 14 to 42 flutes, hard-cut geometry
- Integrated shank cooling + wiper design or shank + inner cooling + wiper design
- For wet pre-finishing/finishing of solid carbide, ceramics
- Also suitable for machining copper
- Neck extension or reduction of total length upon request



Article number	d1	d2	r	l1	l2	d	l	Z
966P.T14.0200.005.020	2.0	1.9	0.05	1.0	2.0	6.0	50	14
966P.T21.0300.005.030	3.0	2.9	0.05	1.0	3.0	6.0	50	21
966P.T28.0400.005.050	4.0	3.9	0.05	1.0	5.0	6.0	50	28
966P.T35.0500.005.050	5.0	4.9	0.05	1.0	5.0	6.0	50	35
966P.T42.0600.005.050	6.0	5.7	0.05	1.0	5.0	6.0	50	42

1

anzelheit A

MARLIN 3D

LASER SERIES

($\varnothing 1,57 \pm 0,02$)

R $\pm 0,01$



971P.0110.05

d h5

MARLIN 971P SERIES

- PCD twist drill, 2 flutes, hard-cut geometry
- Integrated shank cooling
- For wet or dry drilling of solid carbide, ceramics
- Also suitable for machining copper
- Neck extension or reduction of total length upon request



Article number	d1	l1	l4	d	l	Z
971P.0050.04	0.50	2.0	2.5	4.0	43	2
971P.0060.04	0.60	2.4	2.5	4.0	43	2
971P.0070.04	0.70	2.8	2.9	4.0	43	2
971P.0080.04	0.80	3.2	3.3	4.0	45	2
971P.0090.04	0.90	3.6	3.7	4.0	45	2
971P.0100.04	1.00	4.0	4.1	4.0	45	2
971P.0110.05	1.10	5.5	5.6	4.0	47	2
971P.0120.05	1.20	6.0	6.1	4.0	47	2
971P.0130.05	1.30	6.5	6.6	4.0	47	2
971P.0140.05	1.40	7.0	7.1	4.0	47	2
971P.0150.05	1.50	7.5	7.6	4.0	47	2
971P.0160.05	1.60	8.0	8.1	4.0	50	2
971P.0170.05	1.70	8.5	8.6	4.0	50	2
971P.0180.05	1.80	9.0	9.1	4.0	50	2
971P.0190.05	1.90	9.5	9.6	4.0	50	2
971P.0200.05	2.00	10.0	10.1	4.0	50	2

anzelheit A

MARLIN 3D

LASER SERIES

($\emptyset 1,57 \pm 0,02$)

R1 $\pm 0,01$

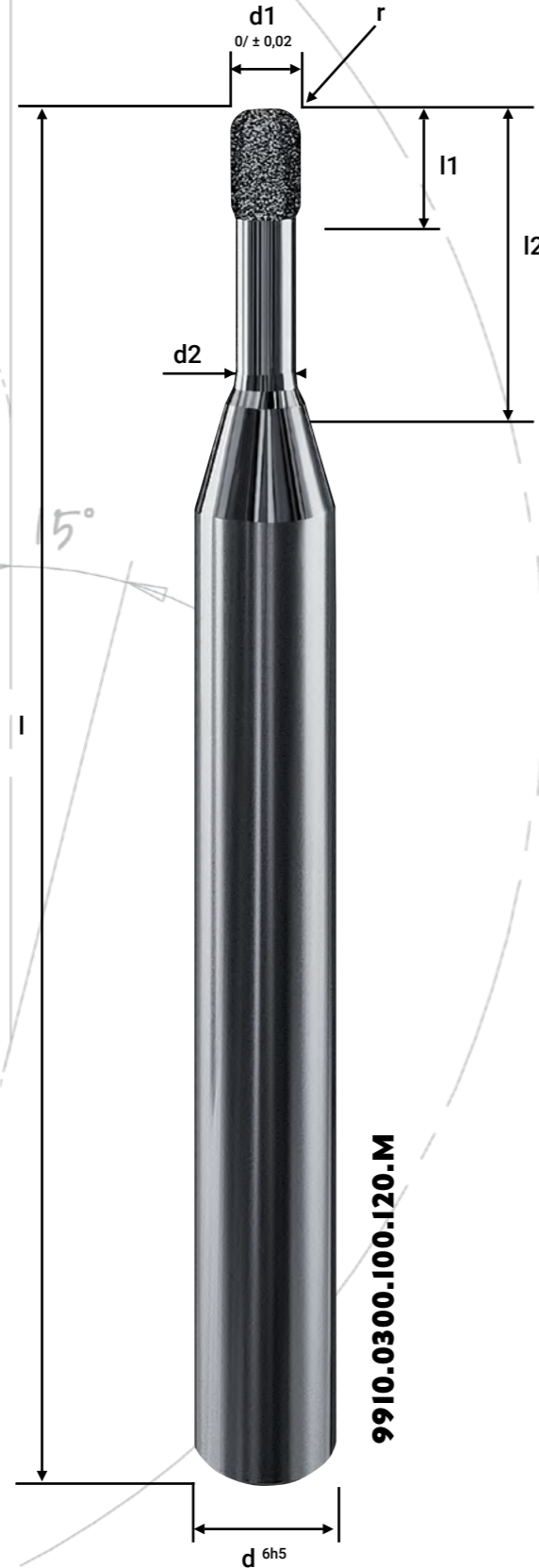

9910.0300.100.120.M

d ^{6h5}

MARLIN 9910 SERIES

- Toric grinding pin
- Processed diamond coating for uniform grit height
- For wet roughing of solid carbide
- Neck extension or reduction of total length available upon request



Article number	d1	d2	r	l1	l2	d	l
9910.0100.010.040M	1.0	0.70	0.10	2.0	4.0	6.0	62
9910.0150.015.060M	1.5	1.25	0.15	3.0	6.0	6.0	62
9910.0200.020.080M	2.0	1.70	0.20	3.0	8.0	6.0	62
9910.0250.050.080M	2.5	2.15	0.50	4.0	8.0	6.0	62
9910.0300.020.120M	3.0	2.70	0.20	4.5	12.0	6.0	62
9910.0300.100.120M	3.0	2.60	1.00	4.5	12.0	6.0	62
9910.0400.050.160M	4.0	3.60	0.50	6.0	16.0	6.0	62
9910.0400.150.160G	4.0	3.50	1.50	6.0	16.0	6.0	62
9910.0500.050.200M	5.0	4.60	0.50	7.5	20.0	6.0	62
9910.0600.050.240M	6.0	5.60	0.50	9.0	24.0	6.0	62
9910.0600.200.240G	6.0	5.50	2.00	9.0	24.0	6.0	62

Parameter reference points:

- Speed min. 32.000 rpm (40.000 recommended)
- Use of emulsion is recommended
- The grinding technology reproduces maximum accuracy of +/- 0.02 mm in \emptyset

anzelheit A

MARLIN 3D

LASER SERIES

($\emptyset 1,57 \pm 0,02$)

R1 $\pm 0,01$

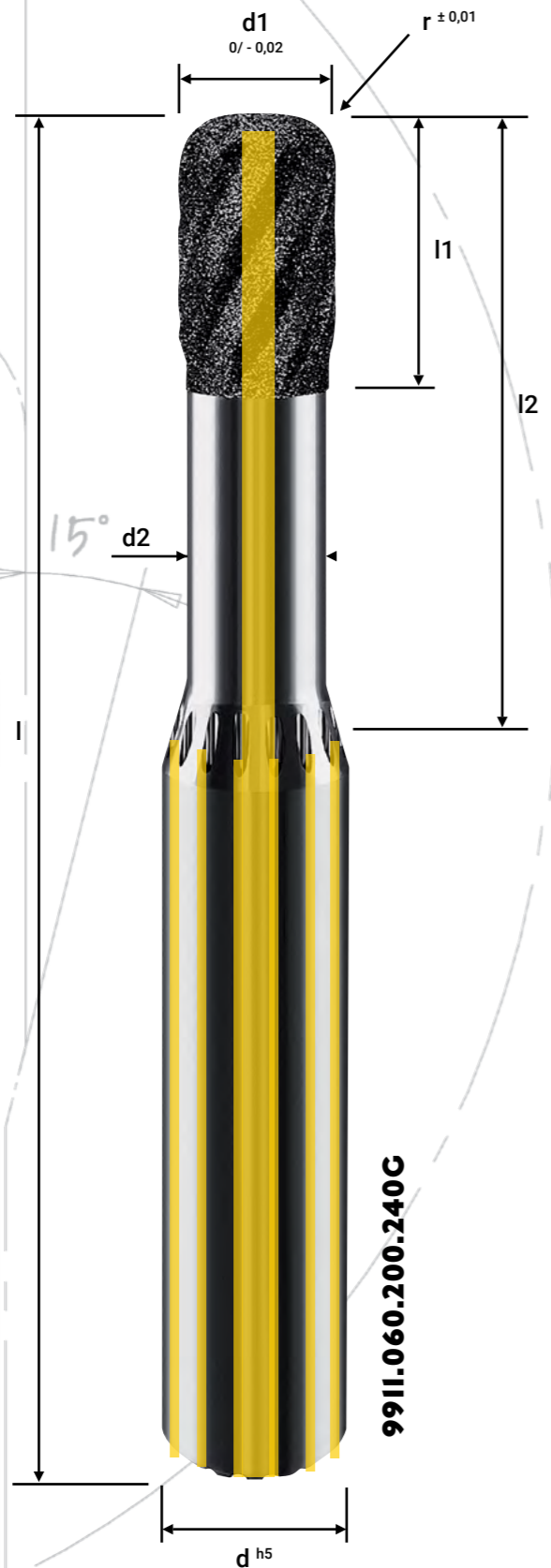

9911.060.200.240G

MARLIN 9911 SERIES

- Toric grinding pin
- Processed diamond coating for uniform grit height
- Integrated shank + internal cooling
- For wet roughing of solid carbide
- Neck extension or reduction of total length available upon request



Item number	d1	d2	r	l1	l2	d	l
9911.0100.010.040F	1.0	0.70	0.1	2.0	4.0	6.0	60
9911.0200.020.080M	2.0	1.70	0.2	3.0	8.0	6.0	60
9911.0300.020.120M	3.0	2.70	0.2	4.5	12.0	6.0	60
9911.0400.020.160M	4.0	3.60	0.2	6.0	16.0	6.0	60
9911.0400.050.160M	4.0	3.60	0.5	6.0	16.0	6.0	60
9911.0400.150.160G	4.0	3.50	1.5	6.0	16.0	6.0	60
9911.0600.020.240M	6.0	5.60	0.2	9.0	24.0	8.0	60
9911.0600.050.240M	6.0	5.60	0.5	9.0	24.0	8.0	60
9911.0600.200.240G	6.0	5.50	2.0	9.0	24.0	8.0	60

Parameter reference points:

- Speed min. 32.000 rpm (40.000 recommended)
- Use of emulsion is recommended
- The grinding technology reproduces maximum accuracy of +/- 0.02 mm in \emptyset

MARLIN 3D

LASER SERIES

(Ø 1,57 ±0,02)

R | ±0,01

SERIES OVERVIEW

Some variations are available under the MARLIN 3D LASER SERIES, which we break down below. Here you will find a brief explanation of the tool series as well as relevant symbols for the properties of the tools. More information about the series and a legend to the symbols can be found on the following pages.

Series	Suitable Materials			Suitable Machining Processes							Blank-Material / Coating			Tool design					
	Carbide	Ceramic	Copper	Drilling	Roughing	Preliminary layers	Finishing	HSC	Dry	Wet	CVD	PCD	DIA	Geometry	Flutes	Internal cooling	Shaft cooling	Wiper	Measurement protocol
960C	xx ¹	xx	x			x	x	x	x	x	x			Ball	2		x		x
962P.T	xx	xx	x			x	x	x		x		x		Toric	3 - 9		x	x ²	x
966P.T	xx	xx	x			x	x	x		x		x		Toric	14 - 42	x ²	x	x	x
971P	xx	xx	x	x				x	x	x		x		Twist drill	2		x		x
9910	xx	xx			x			x		x			x	Toric	Grinding pin				x
9911	xx	xx			x			x		x			x	Toric	Grinding pin		x		x

1 „xx“ indicates that it is optimally designed for processing this material, „x“ indicates that it also works in this material.

2 not available for all tools in the series

anzelheit A

MARLIN 3D

LASER SERIES

ICON LEGEND

- Icons represent Primary Recommended Materials
- Icons represent Secondary Recommended Materials
- Icons to represent the tool design properties
- Icons to represent tool coating
- Icons to represent the indication types of the tool

ICONS APPEARING IN THIS FLYER

Material

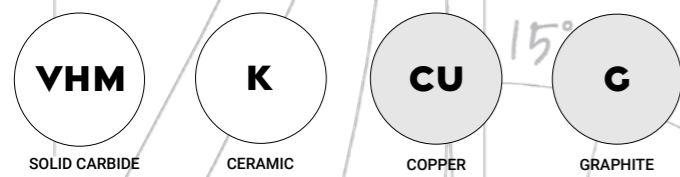

Coating or material of the flute/coating



Tool properties

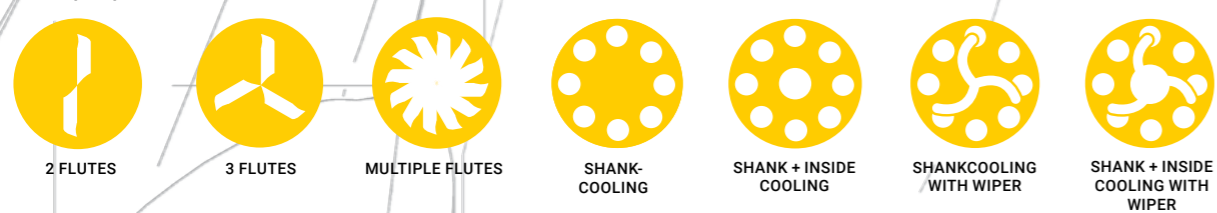

Recommended use

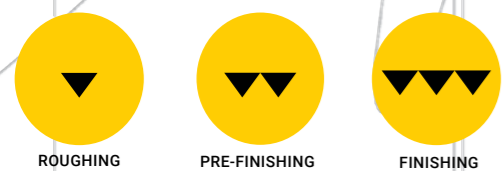

FURTHER INFO

Safety instructions:

1. Observe spindle load limits (depending on manufacturer and type)
2. Observe run-in and warm-up instructions
3. Avoid collision
4. Continuous load can be monitored via current consumption of the spindle
5. Peak load can be monitored via vibration sensor
6. Combine tools and spindle size proportionally
7. High heat generation is possible if the diamond coating fails

AWARD-WINNING: AWARDS FOR OUTSTANDING PERFORMANCE

Only with motivated, positive thinking and independent personalities can a company exist and grow together on new challenges. ZECHA is proud of all its employees for their tireless commitment, passion for progress and willingness to actively contribute to innovation. The awards are the result of creative collaboration and a tribute to the industry.



INNOVATION AWARD OF THE STATE OF BADEN-WÜRTTEMBERG

In 2021, ZECHA Hartmetall-Werkzeugfabrikation GmbH was awarded the Innovation Prize of the State of Baden-Württemberg for the first time. The prize was awarded for the development of a tool family with diamond-coated micro-precision tools that offer outstanding performance in machining the most demanding materials with smooth surfaces. These achievements set new standards worldwide in the field of precision tools.



TOP 100-AWARD

With its outstanding innovation management, ZECHA Hartmetall-Werkzeugfabrikation GmbH receives the TOP 100 seal 2023, an award that is only given to particularly innovative medium-sized companies. The competition is based on a scientific selection process. The decisive factor is whether a company's innovations are random or systematically planned and will be repeatable in the future.

MARLIN 3D

LASER SERIES

(\varnothing 1,57 \pm 0,02)

R1 \pm 0,01



ZECHA

außergewöhnlich.



anzelheit A

THE NEW ZECHA BRANDING

Over the years, brands consistently evolve and transform to meet the changing needs and preferences of their consumers. In the competitive landscape of 2024, ZECHA is poised to introduce its new brand identity, marking a significant milestone in its journey. The unveiling of the ZECHA branding represents a culmination of the brand's growth and commitment to excellence.

At the core of the new ZECHA logo lies a perfect circle, which symbolizes the meticulous process of the first step in the process of making all tools at ZECHA which is grinding tools into flawless cylinders. This iconic image embodies ZECHA's

dedication to precision and quality. It signifies the brand's unwavering pursuit of perfection, ensuring that every tool manufactured by ZECHA is perfectly concentric, guaranteeing superior performance.

In the new branding, ZECHA also integrates the word "außergewöhnlich" into various visuals. Derived from the German language, "außergewöhnlich" translates to "extraordinary" in English. This carefully chosen word encapsulates the overarching goal of every product created by ZECHA. It signifies the brand's commitment to delivering exceptional tools that surpass.

The ZECHA Logo through the years:

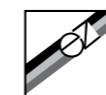

TOP
100

top100.de

Top-Innovator
2023

ZECHA'S COMMITMENT TO EXCELLENCE

OVER HALF A CENTURY OF PRECISION

ZECHA Hartmetall-Werkzeugfabrikation GmbH is a precision tool manufacturer that has been in Baden-Württemberg, Germany for 60 years. With a focus on manufacturing high quality micro tools, we pride ourselves on providing our customers with the highest level of precision and consistency in our products. Our state-of-the-art manufacturing and measurement technologies allow us to maintain the highest quality standards and ensure that our tools meet our customers' needs.

With a focus on innovation and the constant research of new technologies, we improve the precision and efficiency of our tools. This philosophy allows us to stay at the forefront of the industry and provide our customers with state-of-the-art solutions for their tooling needs.

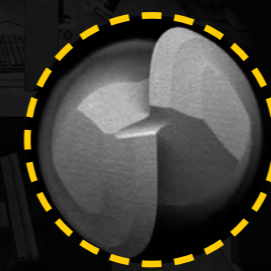

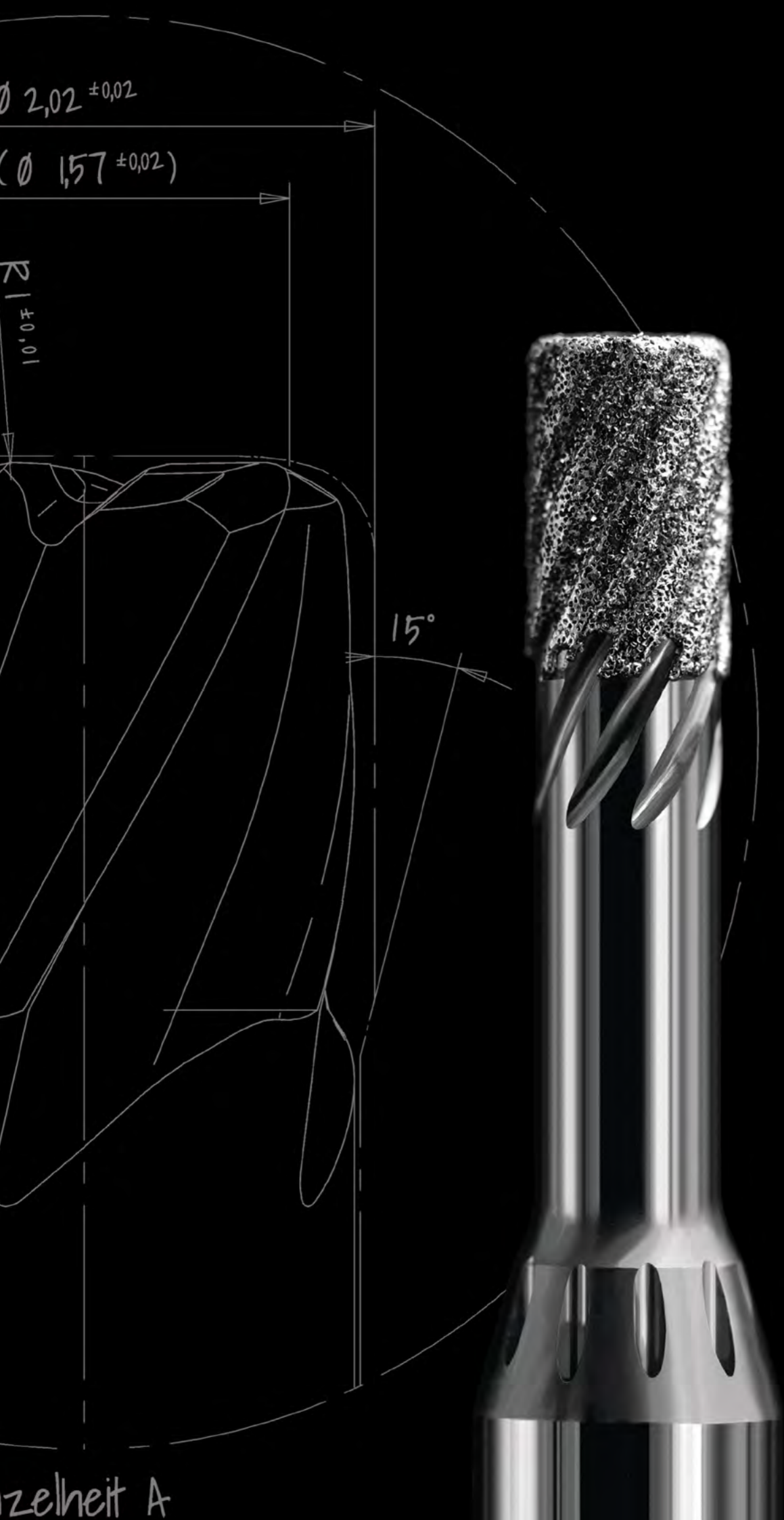

zeit A



ZECHA
außergewöhnlich.



Z ZECHA

ZECHA Hartmetall-Werkzeugfabrikation GmbH
Benzstraße 2, D-75203 Königsbach-Stein
+49 7232 3022 0
www.zecha.de, info@zecha.de

